



USER MANUAL



POWER BREEZER

MACH 4+

MAX+

TITAN+

Version 1.0
For use with models:
PB4BASE, PB4MAX and PB4TITAN
Serial Numbers: PB-60069459 and higher

Congratulations on your selection of a Power Breezer® evaporative cooler.

We are proud of our products and have designed your Power Breezer for years of safe, reliable service. This user manual will instruct you in the proper operation and maintenance of your Power Breezer. Please read through this manual before operating your Power Breezer.

SAVE THIS MANUAL

TABLE OF CONTENTS

WARNINGS	3
I. KEY COMPONENTS	4
II. SETUP	6
1. Mounting the fan head:	6
2. Using the correct outlet:	10
3. Adding water to the water tank:	10
4. Routing power and water lines and replacing tank lid:	11
III. OPERATION	12
1. Control panel – Buttons:	12
2. Turning on your Power Breezer:	12
3. Adjusting the misting level:	13
IV. DISASSEMBLY	14
1. Power off:	15
2. Drain water tank:	15
3. Dismounting fan head:	16
4. Routing power and water lines and replacing tank lid:	19
V. TRANSPORTING YOUR POWER BREEZER	20
VI. MAINTAINING YOUR POWER BREEZER	20
Cleaning Process:	20
Monthly or Quarterly:	21
Semi-Annually:	21
VII. WARRANTY	22
IX. CONTACT INFORMATION	24



WARNINGS

- This Power Breezer is intended for use only as specified in this manual. If you have questions about its use, please contact Power Breezer. 844.233.5673 | customerservice@powerbreezer.com
- Use only on a outlet protected by a ground-fault circuit-interrupter (GFCI). (see page 10)
- Avoid using extension cords.
- Do not allow to become wet. Do not plug in while hands are wet. Doing so causes risk of electric shock.
- Do not alter the plug in any way.
- If the power cord is damaged, do not attempt to repair it yourself. Contact Power Breezer customer service for assistance. 844.233.5673 | customerservice@powerbreezer.com
- Turn off and unplug the Power Breezer prior to filling or emptying water reservoir.
- Turn off and unplug the Power Breezer prior to moving.
- Turn off and unplug the Power Breezer prior to cleaning it.
- Always unplug the Power Breezer by pulling on the plug and never on the cord.
- Do not insert fingers or other objects inside the fan head, doing so may cause bodily injury.
- Children can fall into open water reservoir and drown, even in a small amount of water. Keep children away from reservoir. Keep the water tank lid on at all times.
- Closely supervise nearby children and pets when using this Power Breezer. Do not leave Power Breezer unattended.
- Children shall not play with the Power Breezer.
- Cleaning and user maintenance shall not be made by children without supervision.
- The Power Breezer is not to be used by persons (including children) with reduced physical, sensory or mental capabilities, or lack of experience and knowledge, unless they have been given supervision or instruction.
- This Power Breezer can be used by children aged from 8 years and above and persons with reduced physical, sensory or mental capabilities or lack of experience and knowledge if they have been given supervision or instruction concerning use of the Power Breezer in a safe way and understand the hazards involved.
- When operating Power Breezer, use common sense. Stay clear of moving parts. NEVER touch the any portion of the Atomizer while it is spinning, doing so may cause bodily injury. Only use water that is safe for drinking.
- If the Power Breezer becomes damaged or malfunctions, do not attempt to repair the Power Breezer. Doing so will void the warranty. Contact Power Breezer customer service for repair assistance. 844.233.5673 | customerservice@powerbreezer.com
- The appliance is not to be used by persons (including children) with reduced physical, sensory or mental capabilities, or lack of experience and knowledge, unless they have been given supervision or instruction or equivalent.
- This Power Breezer is suitable for use as a fan for tropical climates.
- This Power Breezer is suitable for use outdoors.
- This Power Breezer is intended for industrial use.
- This Power Breezer is rated IP24.
- Do not throw away this user manual, keep it for reference.

I. KEY COMPONENTS

Front View



Rear View

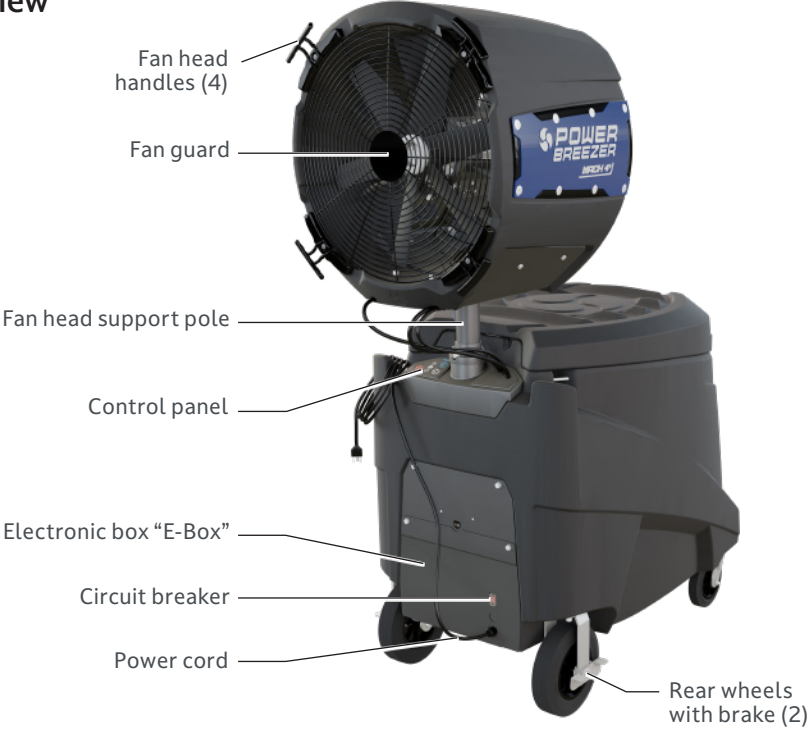

Control Panel

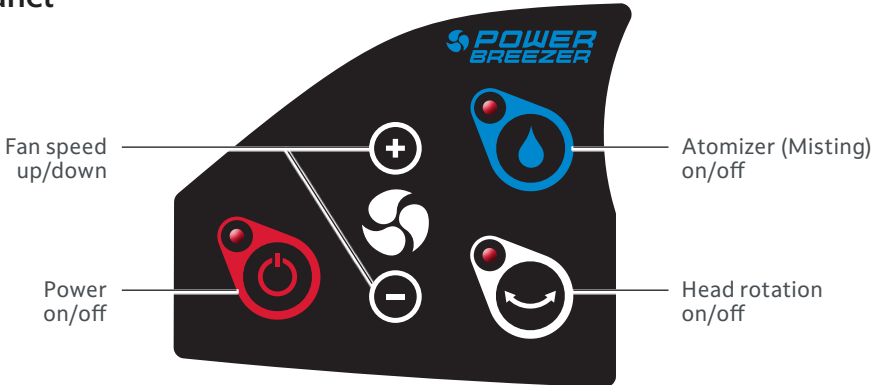

Storage View

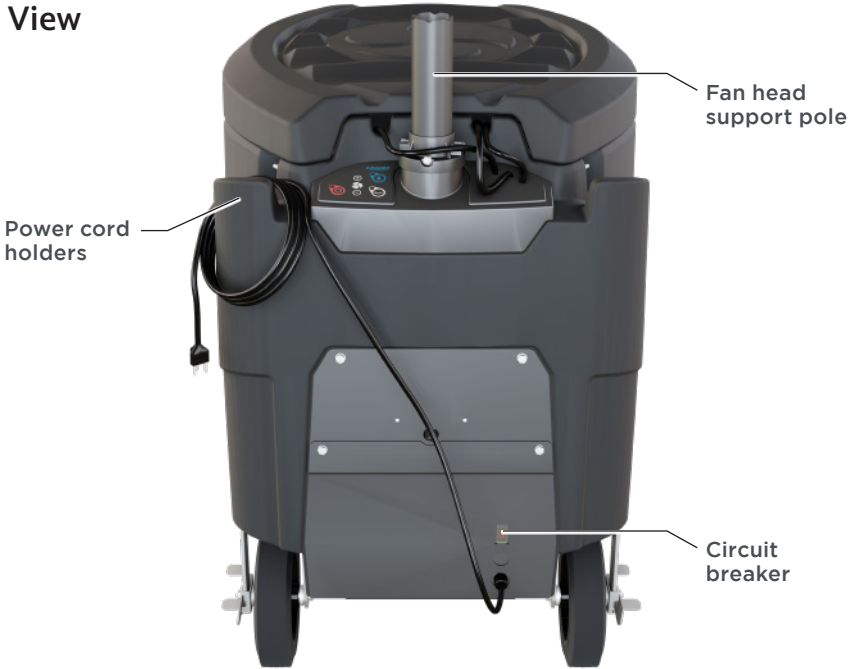

Inside Water Tank View

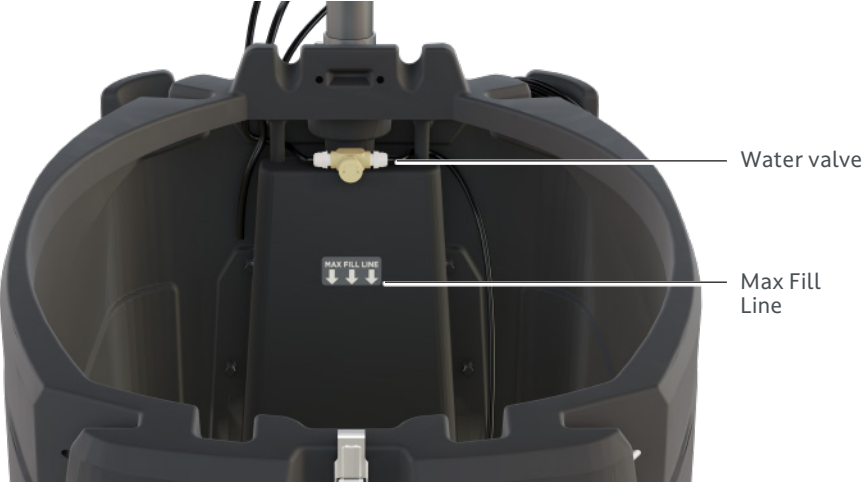

II. SETUP

1. Mounting the fan head:



To set up your Power Breezer, you will need:

- 2 people
- An AC outlet
- Access to water to fill the **water tank**

Remember:

- Lift **fan head** only by the **head handles**.
 - **Never** lift from the **fan guards**.
 - The **fan head** weighs 86 lbs.
1. Before you get started, be sure to **lock both** of the **rear wheels** by pressing down on the brake lever to set them to the **ON** position.



2a. Open the **lid latch** by first pulling forward the lower portion of the latch.



2b. Finish opening the **lid latch** by pulling the upper portion of the latch forward and away from the **tank lid**.



3. Remove **tank lid** by first lifting up on the **transport handle** and then pulling forward.



4. Tilt up the four **fan head handles**, if they are folded down, prior to lifting the **fan head**.



5a. To lift the **fan head** out of the **water tank**, each person should stand on opposite sides of the Power Breezer.

5b. Both people should grasp the **fan head** by the **fan head handles**, as shown.

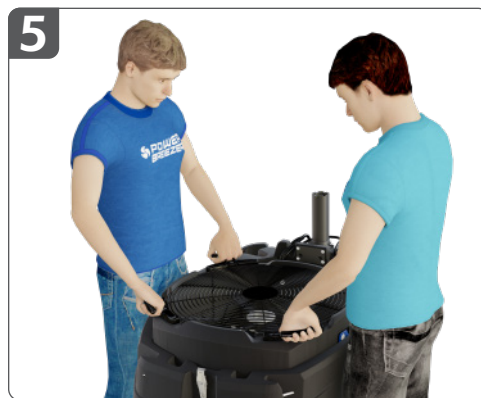

Remember:

- Lift **fan head** only by the **head handles**.
- **Never** lift from the **fan guards**.

6a. Lift the **fan head** straight up and out of the **water tank**. Carefully rest it on the edge of the **water tank**.



6b. Both people should re-adjust their grip so that they have one hand on a **fan head handle** or the black outer housing and one hand on the front edge of the **fan head**, as shown.



NOTE: Install the **fan head** so that the **fan head power cord** and **water hoses** are positioned in back of the **fan head support pole**.

NOTE: There is an arrow located on each side of the **fan head saddle** (see inset image). Use these arrows as visual aids to help align the **fan head** to the **fan head support pole**.

6c. Once again, lift the **fan head** and align it with the **fan head support pole**. Once the **fan head** is seated on the **fan head support pole**, rotate the **fan head** horizontally until you feel it engage with the **fan head support pole**.

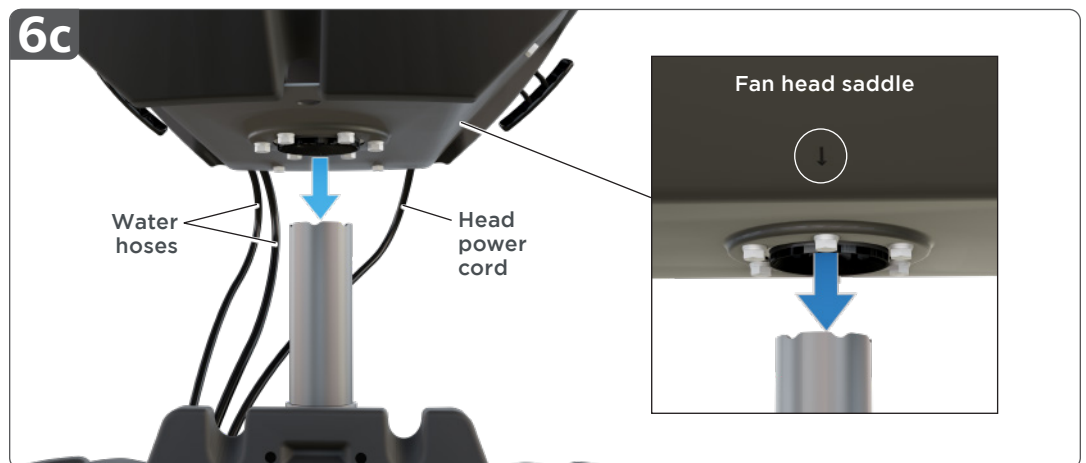

NOTE: Do not install or rotate the **fan head** so that it faces the rear of the unit. Doing so may make the unit unstable and will damage it.

When the **fan head** is installed correctly, the **atomizer (metal disk)** will be facing the **water tank**, air will be blown over the **water tank** when the Power Breezer is in use.



2. Using the correct outlet:

Electrical current of 110v or 220v is required. (see page 20 for Electrical Requirements)

For safety, only plug your Power Breezer into an power outlet equipped with GFCI.

DO NOT plug into standard power outlet without a GFCI feature.

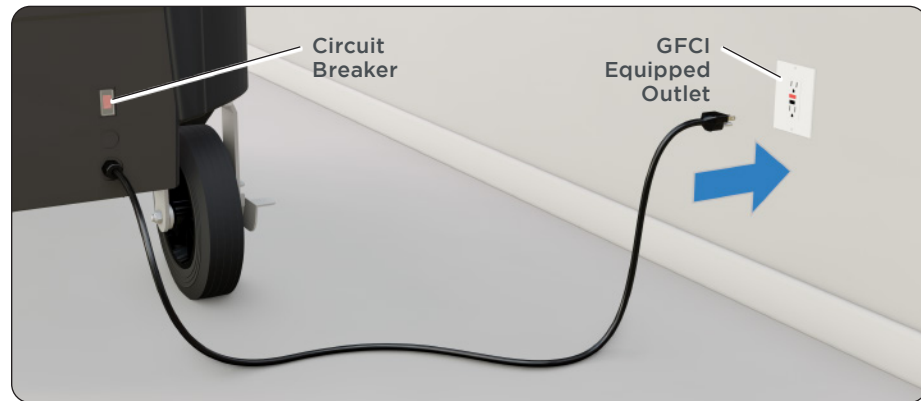

NOTE: A power outlet can be verified that it is functioning when the Power Breezer is plugged into it. If functioning, the **Circuit Breaker** on the Power Breezer will illuminate.

If the **Circuit Breaker** does not illuminate:

- Try another known to be functioning outlet.
- Press the top portion of the **Circuit Breaker's** button to reset.
- If it still is not illuminating visit Power Breezer's Knowledgebase trouble shooting guides: www.powerbreezer.com/knowledgebase_categories/troubleshooting-guides/

WARNING: Do not add any additives of any kind to the water being used for cooling.

The introduced additive(s) when run through the **atomizer**, will become aerosolized which may cause eye, lung and skin hazards.

Doing so may also damage the unit.

3. Adding water to the water tank:

Add only potable water to the **water tank**. In order for the **Atomizer** to function, the water in the **water tank** must be at a high enough water level so that the water pump is fully emersed. Do not fill the **water tank** above the **max fill level**, as shown. If **water tank** is filled past this level, water may leak out of the **water tank** and cause a hazard around the Power Breezer.



The **water valve** can be adjusted for optimal performance according to your climate. To adjust, please follow the steps in the **Operation - Adjusting the misting level** section of this manual.

4. Routing power and water lines and replacing tank lid:

1. Route the **fan head power cord, atomizer drain hose, and water inlet hose** through the openings in the back of the **water tank** as shown below.



NOTE: There are **tank lid tabs** on the back underside of the **tank lid**.

- 2a. Slide the **tank lid tabs** into the corresponding **water tank notches** in the back of the **water tank** as shown below.

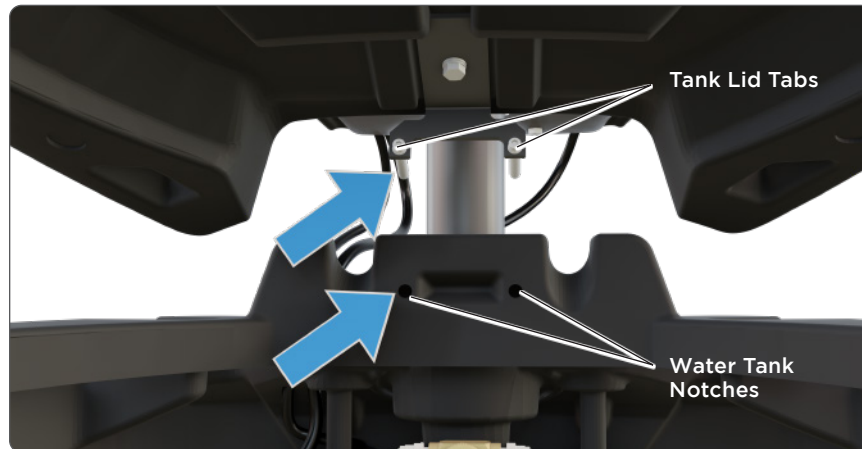







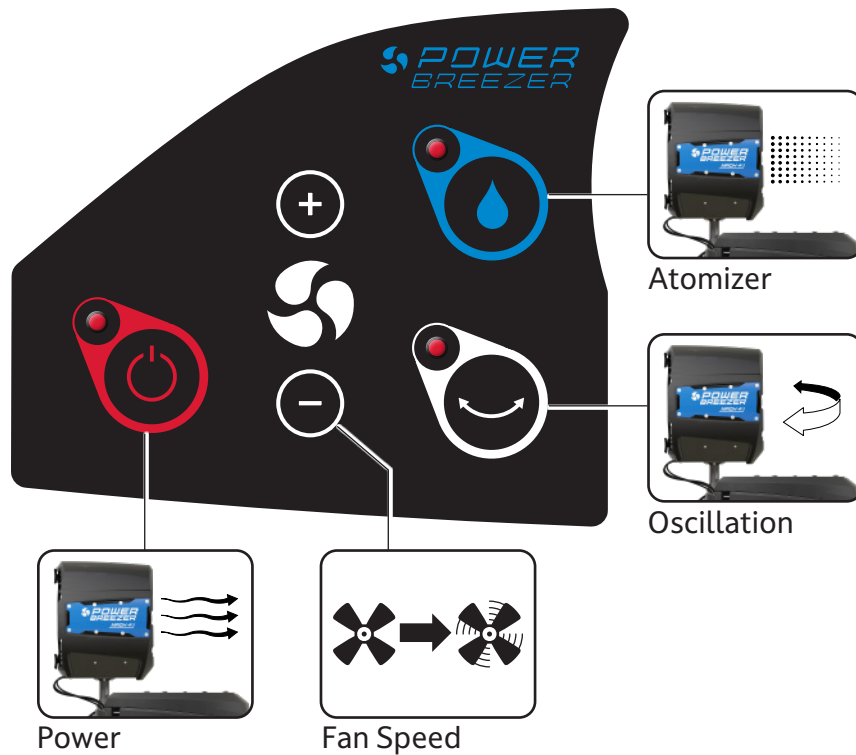

- 2b. Lower the front of the **tank lid** onto the **water tank** and re-lock the **lid latch**.

III. OPERATION

1. Control panel – Buttons:



2. Turning on your Power Breezer:

1. Press the **power button**  and **hold for one second**.
The LED light for the **power button** will be lit and the fan blades will begin to slowly rotate to indicate the Power Breezer is powered on.
2. Press the fan **speed button**  to increase the fan speed.
Adjust the fan speed by pressing the  or  buttons.
3. Press the **oscillation button**  once to activate the oscillation feature.
The LED light for the oscillation button will be lit. Press **oscillation button**  again to stop fan head at a desired angle.
4. Press the **atomizer button**  once to activate the misting feature.
The LED light for the atomizer button will be lit. Press **atomizer button**  again to stop.

Memory Feature:

Your Power Breezer is equipped with a memory feature that when it is powered off it will remember the settings of its last use.

When the **power button**  is pressed again, it will power back to the same **fan speed, oscillation, and atomizer settings** of its last use.

The Power Breezer's memory feature and any previous settings will be reset if it is unplugged.



CAUTION

When the Power Breezer is powered back on, the **fan head** may resume oscillating.

- **Prior to powering the Power Breezer back on**, the person operating it and any people standing near it should maintain a safe physical distance from the **fan head**.
- **Prior to powering the Power Breezer back on**, make sure it has sufficient free space around it to prevent the oscillating **fan head** coming in contact with nearby objects.



WARNING

NEVER touch any portion of the Atomizer while it is spinning.

Doing so may cause bodily injury.





NOTE: When the atomizer button is on and no mist is being produced it could be several reasons:

- Check to see if there is sufficient water in the tank to cover the pump. The water pump has an auto shutoff feature that activates when low or no water is detected.
- Check to verify the water valve is set to an open position.

3. Adjusting the misting level:

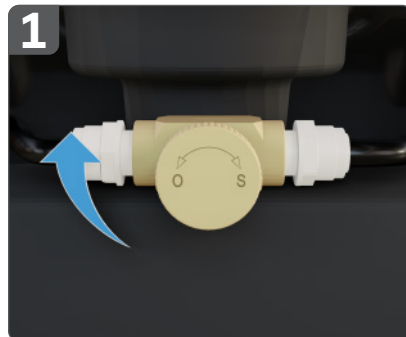
- 1a.** Press the **power button**  and hold for one second if Power Breezer is not already on.
- 1b.** Set **fan speed** to desired level.
- 1c.** Locate the **water valve** inside and towards the rear of the **water tank**.
- 1d.** Start with the **water valve** closed, by turning the knob clockwise until it stops turning.



1e. Start the **atomizer** by pressing the **atomizer button**  once.

NOTE: The water valve's full range of adjustment (closed <-> open) takes approximately 5 complete turns (360°) of the knob to totally open or close the valve.

2a. Open the **water valve** by turning the lever counter-clockwise several full turns. There will be a short delay before misting begins. Check the distance of the mist.

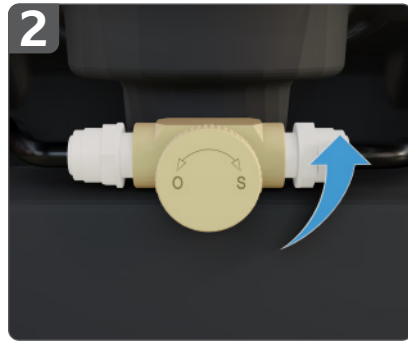

2b. If there is a strong mist at 6 feet away, then the moisture setting is too high for conditions. To reduce misting, rotate the **water valve** knob clockwise.

Optimal moisture settings can also be adjusted according to personal preference.

IV. DISASSEMBLY



To disassemble your Power Breezer, you will need:

- 2 people

1. Power off:

- 1a. Power off the Power Breezer by holding down the **power button**  for one second.
- 1b. Unplug the **power cord**.



2. Drain water tank:

WARNING: Do not drain water tank in a location where the drained water will create a slip hazard.

Depending on the volume of water to be drained, you may want to move your Power Breezer to a suitable location prior to draining.

Open the **drain plug** by turning counter-clockwise and fully drain the water tank (located at the lower front of the **water tank**).

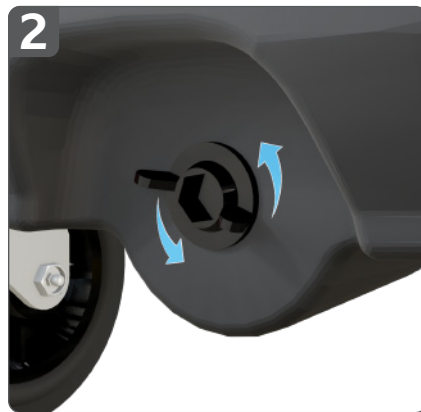

3. Dismounting fan head:

1. Before you get started, be sure to **lock both** of the **rear wheels** by pressing down on the **brake lever** to set them to the **ON** position.



- 2a. Open the **lid latch** by first pulling forward the lower portion of the latch.



- 2b. Finish opening the **lid latch** by pulling the upper portion of the latch forward and away from the **tank lid**.



3. Remove **tank lid** by first lifting up on the **transport handle** and then pulling forward.



Remember:

- Lift **fan head** only by the **head handles** or the black outer shell.
- **Never** lift from the **fan guards**.
- The **fan head** weighs 86 lbs.

3a. Lift the **fan head** straight up and off the **head support pole**.





CAUTION

3b. Carefully rest the **fan head** on the edge of the **water tank**.

PINCH POINT: When placing the **fan head** on the edge of the **water tank**, keep hands clear as to not get them pinched between the **fan head** and **water tank** as they make contact with each other.



3c. Once the **fan head** is resting on the edge of the **water tank**, both people should adjust their grasp so they are holding the **fan head handles**, as shown below.



Remember:

- Lift the **fan head** only by the **head handles**.
- **Never** lift from the fan guards.

3d. Carefully lower the **fan head** into the **water tank**.

4. Routing power and water lines and replacing tank lid:

1. Route the fan head power cord, atomizer drain hose, and water inlet hose through the openings in the back of the **water tank** as shown below.



NOTE: There are **tank lid tabs** on the back underside of the **tank lid**.

- 2a. Slide the **tank lid tabs** into the corresponding **water tank notches** in the back of the **water tank** as shown below.

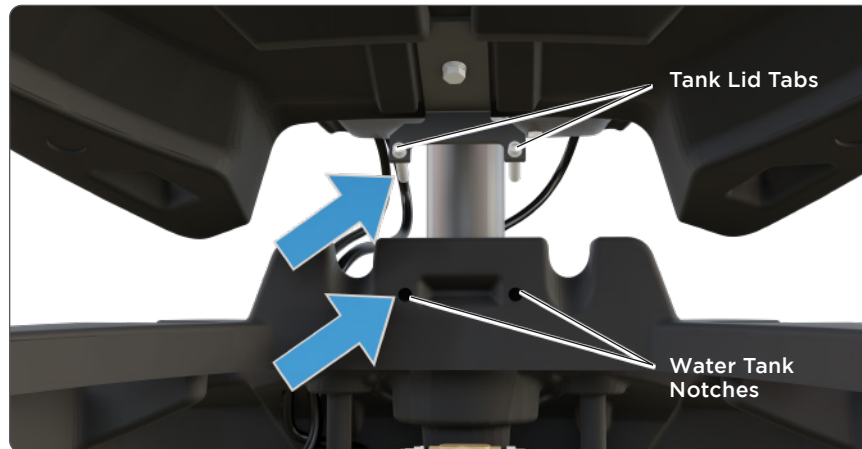

- 2b. Lower the front of the **tank lid** onto the **water tank** and re-lock the **lid latch**.

V. ELECTRICITY FOR YOUR POWER BREEZER

Your Power Breezer Mobile Unit is designed so that it can be used in either a 110v or 220v electrical systems **depending on the model.**

Electrical Requirements:

Model	PB4BASE	PB4MAX	PB4TITAN
Voltage	110v	110v	110v–220v Universal

NOTE: It is **not recommended** to use **power plug adaptors for the PB4BASE and PB4MAX** models. Doing so may damage the unit and or void the warranty.

PB4TITAN Electrical Options:

There are two options available to use your Power Breezer Titan in a local electrical system/ voltage that differs from the unit's original electrical usage intent.

(For example: 110v, Plug Type G, United States' standard three prong)

Option 1 – Order a replacement power cord that matches the new electrical system and outlet*:

Order online at:

<https://www.powerbreezer.com/parts/>

Or contact your retail seller or distributor.

*Note: Limited types of power cord types are produced and not every configuration is available.

Option 2 – Power Plug Adaptor:

Usage Recommendations: for units used in **NON** Military and or Industrial settings.

Power Plug Adaptor Electrical Certification: Only use ETC, CE UL or equivalent electrically certified devices that are rated for the voltage to be used. Refer to the power plug adaptor manufacturer's specifications and recommended applications prior to use.

Materials required – one of the following:

- 110v to 220v power plug adaptor
- 220v to 110v power plug adaptor
- Universal power plug adapter

VI. TRANSPORTING YOUR POWER BREEZER

DO NOT reposition or move your Power Breezer by the **fan head** (if mounted) or the **fan head support pole** (if stored). Doing so may damage your Power Breezer. Only reposition or move your Power Breezer by the **transport handle**.

Prior to transporting your Power Breezer over long distances or by transport vehicle, disassemble the Power Breezer to prevent damage. Use the **tie down points** to limit movement and prevent damage. Also make sure both **rear wheel locks** are engaged in the **ON position** to prevent rolling.

VII. MAINTAINING YOUR POWER BREEZER

Your Power Breezer is made with LDPE. LDPE has good chemical resistance, high impact strength, and strong wear absorption. LDPE can hold food products without leaching any harmful materials or allowing microorganisms to permeate.

Once/week, drain the **water tank** until empty, remove the lid, and let the **water tank** completely dry inside.

Ideally, clean the **water tank** once a week (at very minimum once a month) with a light dish detergent and water, this will keep the Cooling Unit operating clean and odor-free.

Cleaning Process:

- Drain the **water tank** (unscrew the **drain plug** at the lower front of the **water tank**)
- Clean the interior of the **water tank** only with light dish detergent and water. A plastic (not metal) dish or toilet style brush can be used.
- Rinse thoroughly.
- Let air dry with the **water tank lid** off or wipe dry with a towel.
- Reseal **water tank** with **drain plug**, add water and operate as needed.
- Clean the outside with light dish detergent and water. Do not use harsh chemicals or abrasives.

Monthly or Quarterly:

NOTE: If you have excessively hard or sandy water, monthly cleaning is recommended.

- Drain the **water tank** (unscrew the **drain plug** at the lower front of the **water tank**)
- If there is white calcium or sand build upon the interior of the water tank, scrub with a brush and rinse out
- Let air dry with the **water tank lid** off or wipe dry with a towel
- Reseal **water tank** with **drain plug**, add water and operate as needed.

Semi-Annually:

Water Pump Maintenance (MIV and Newer)

- Remove the water pump from the water tank.
- Open the filter cage on the inlet side of the water pump.
- Make sure the filter (black sponge) is clear of debris.
- Replace the cover.
- Place the water pump back in the water tank.

VIII. WARRANTY

Power Breezer 1 Year Limited Warranty

WHAT IS COVERED:

Power Breezer. (“Manufacturer”) warrants the following products:

Power Breezer Mobile or **Power Breezer Sky** (“Unit”)

for the Coverage Period of One (1) year for all of the Unit’s components have a warranty to be free from defects in materials or workmanship

WHO IS COVERED:

This Limited Warranty extends only to the first purchaser (“Buyer”) and is not transferable. The Warranty coverage starts from the date of shipment to the Buyer. Under no circumstances will warranty coverage extend to products purchased through eBay, Craigslist, or other internet auction or internet-based retail sites not approved by Manufacturer. This Warranty is only valid within the 50 states of the United States and the District of Columbia.

WHAT WILL THE MANUFACTURER DO:

Within 30 days after receipt of a claim made on a product still within the warrantable Coverage Periods, the Manufacturer shall have the option either to inspect the product while in it is still in the Buyer’s possession or to request the Buyer to return the product to a specified service center at Buyer’s expense for an inspection. Any components found, upon a detailed examination by factory authorized personnel, to be defective in either material or workmanship will be repaired or replaced with functioning new or remanufactured parts at Manufacturer’s or authorized dealer’s option and without a charge. Manufacturer is not responsible for the cost of removal of the defective product or part, damages due to removal, or any expenses incurred in shipping the product or part to or from the Unit’s location, or the installation of the repaired or replaced product or part. Transportation charges on parts submitted for replacement or repair under this warranty shall be borne by the Buyer.

The aforementioned constitutes the extent of your Remedy under this Limited Warranty and the limit of liability for Manufacturer, and for any and all losses in connection with this product.

BUYER'S HOW TO MAKE A CLAIM:

Any and all repairs and replacements must be performed by or under the instruction of the Manufacturer, authorized dealer and or representative. All warranty claims must be made ASAP after a defect is discovered, but before the end of the warranty coverage on that part. When a warranty claim is submitted by the Purchaser and approved by the Manufacturer, the Manufacturer may choose to replace the Unit, ship the Unit to the Manufacturer's warehouse for repair, or dispatch a field service representative to the Purchaser's site for repair.

THESE WARRANTIES ARE THE ONLY EXPRESS WARRANTIES BY MANUFACTURER ON THE UNIT. THESE WARRANTIES ARE LIMITED IN DURATION TO THE TIME PERIOD(S) OF THESE EXPRESSED WRITTEN WARRANTIES. THESE WARRANTIES ARE IN LIEU OF ALL OTHER OBLIGATIONS, LIABILITIES OR WARRANTIES, WHETHER EXPRESS OR IMPLIED. THESE WARRANTIES DO NOT COVER:

- (1) NORMAL DETERIORATION OR FADING OF COLOR, COSMETIC OR APPEARANCE ITEMS;
- (2) DAMAGE OR MALFUNCTION DUE TO IMPROPER REPAIR DUE TO ANY UNAUTHORIZED ALTERATION OR MODIFICATION MADE TO THE UNIT;
- (3) DAMAGE OR MALFUNCTION DUE TO ABUSE, NEGLIGENCE, ACCIDENT OR FIRE;
- (4) DAMAGE CAUSED BY A NON-COVERED, UNAUTHORIZED PART; AND
- (5) FAILURE TO FOLLOW MANUFACTURER'S CLEANING AND MAINTENANCE GUIDELINES. MANUFACTURER AND ITS AUTHORIZED DEALERS AND DISTRIBUTORS SHALL NOT BE LIABLE FOR ANY LOSS OF USE OF THE COOLING UNIT, FOR ANY ALTERNATE EQUIPMENT, FOR ANY DAMAGE TO GOODS, COMMERCIAL LOSS, LOSS OF TIME OR INCONVENIENCE, OR FOR ANY OTHER INCIDENTAL OR CONSEQUENTIAL DAMAGES.

For more information, please visit www.PowerBreezer.com

Make a claim, please visit www.powerbreezer.com/warranty-claim/

IX. CONTACT INFORMATION

General Information or Product/Installation Support

Email: customerservice@powerbreezer.com

Phone: 844.233.5673, Option 1

Visit: www.powerbreezer.com/support

Knowledgebase: www.powerbreezer.com/knowledgebase/

Corporate Headquarters:
4835 Sirona Drive, Suite 400
Charlotte, NC 28273

Google Map: <https://goo.gl/maps/PJuHjSAvNiBxWDvX8>

For Sales Information

sales@powerbreezer.com

Phone: 844.233.5673

User Videos

www.youtube.com/powerbreezer

www.powerbreezer.com

Follow Us

www.linkedin.com/company/2561996

www.facebook.com/PowerBreezer

www.twitter.com/PowerBreezer



PowerBreezer.com

4835 Sirona Drive, Suite 400
Charlotte, NC 28273

©2023 Maxify Solutions, Inc.
All Rights Reserved.

Power Breezer® is licensed under
U.S. Patent No. 6,789,787.

