



# USER MANUAL



**POWER  
BREEZER**

**TITAN+**

*Universal 110v-220v*

Version 4.0

For use with model:  
PB4TITAN

For Serial Numbers up to: PB-60069458

Congratulations on your selection of a Power Breezer® evaporative cooler. We are proud of our products and have designed your Power Breezer for years of safe, reliable service. This user manual will instruct you in the proper operation and maintenance of your Power Breezer. Please read through this manual before operating your Power Breezer.

**SAVE THIS MANUAL**

**TABLE OF CONTENTS**

---

<b>A. WARNINGS</b>	<b>3</b>
<b>I. KEY COMPONENTS</b>	<b>4</b>
<b>II. SETUP</b>	<b>6</b>
1. Mounting the fan head:	6
2. Using the correct outlet:	10
3. Adding water to the water tank:	10
4. Routing power and water lines and replacing tank lid:	11
<b>III. OPERATION</b>	<b>12</b>
1. Control panel – Buttons:	12
2. Turning on your Power Breezer:	12
3. Adjusting the misting level:	13
<b>IV. DISASSEMBLY</b>	<b>14</b>
1. Dismounting fan head:	15
2. Routing power and water lines and replacing tank lid:	17
<b>V. MOVING / TRANSPORTING YOUR POWER BREEZER</b>	<b>18</b>
<b>VI. MAINTAINING YOUR POWER BREEZER</b>	<b>19</b>
1. Maintaining the water tank:	19
2. Maintaining the fan head and motor:	19
<b>VII. ELECTRICITY FOR YOUR POWER BREEZER</b>	<b>20</b>
<b>VIII. WARRANTY</b>	<b>21</b>
<b>IX. CONTACT INFORMATION</b>	<b>23</b>

## A. WARNINGS

- This Power Breezer is intended for use only as specified in this manual. If you have questions about its use, please contact Power Breezer.  
**844.233.5673 | customerservice@powerbreezer.com**
- Use only on a outlet protected by a ground-fault circuit-interrupter (GFCI). (see page 10)
- Avoid using extension cords.
- Do not allow plug to become wet. Do not plug in while hands are wet. Doing so causes risk of electric shock.
- Do not alter the plug in any way.
- If the power cord is damaged, do not attempt to repair it yourself. Contact Power Breezer customer service for assistance.  
**844.233.5673 | customerservice@powerbreezer.com**
- Turn off and unplug the Power Breezer prior to filling or emptying water reservoir.
- Turn off and unplug the Power Breezer prior to moving.
- Turn off and unplug the Power Breezer prior to cleaning it.
- Always unplug the Power Breezer by pulling on the plug and never on the cord.
- Do not insert fingers or other objects inside the fan head, doing so may cause bodily injury.
- Children can fall into open water reservoir and drown, even in a small amount of water. Keep children away from reservoir. Keep the water tank lid on at all times.
- Closely supervise nearby children and pets when using this Power Breezer. Do not leave Power Breezer unattended.
- Children shall not play with the Power Breezer.
- Cleaning and user maintenance shall not be made by children without supervision.
- The Power Breezer is not to be used by persons (including children) with reduced physical, sensory or mental capabilities, or lack of experience and knowledge, unless they have been given supervision or instruction.
- This Power Breezer can be used by children aged from 8 years and above and persons with reduced physical, sensory or mental capabilities or lack of experience and knowledge if they have been given supervision or instruction concerning use of the Power Breezer in a safe way and understand the hazards involved.
- When operating Power Breezer, use common sense. Stay clear of moving parts and only use water that is safe for drinking.
- If the Power Breezer becomes damaged or malfunctions, do not attempt to repair the Power Breezer. Doing so will void the warranty. Contact Power Breezer customer service for repair assistance. **844.233.5673 | customerservice@powerbreezer.com**
- The appliance is not to be used by persons (including children) with reduced physical, sensory or mental capabilities, or lack of experience and knowledge, unless they have been given supervision or instruction" or equivalent.
- This Power Breezer is suitable for use as a fan for tropical climates.
- This Power Breezer is suitable for use outdoors.
- This Power Breezer is intended for industrial use.
- This Power Breezer is rated IP24.
- Do not throw away this user manual, keep it for reference.

# I. KEY COMPONENTS

## Front View

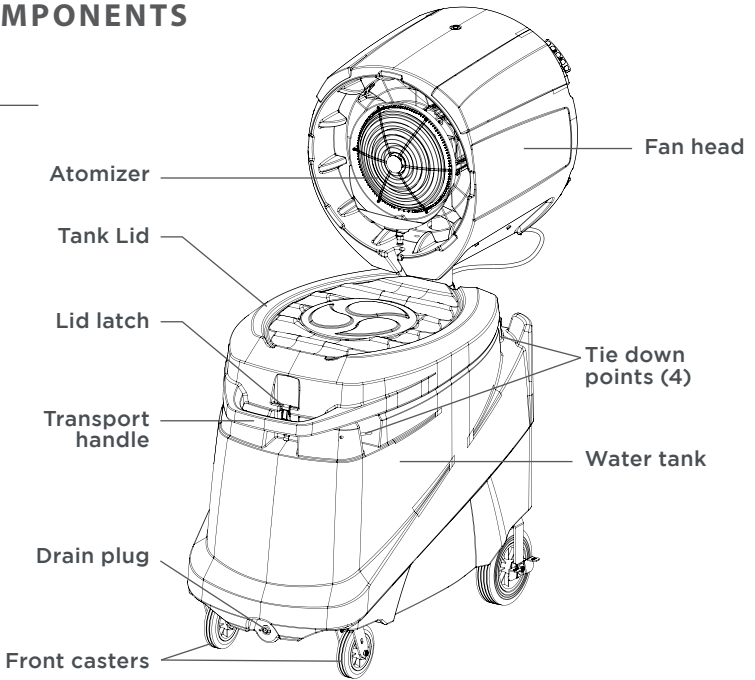

## Rear View

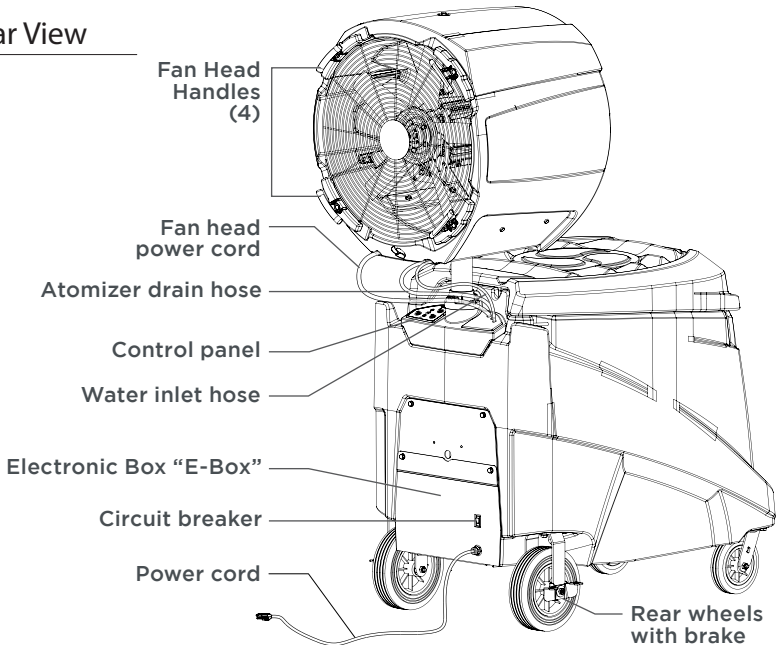

## Control Panel

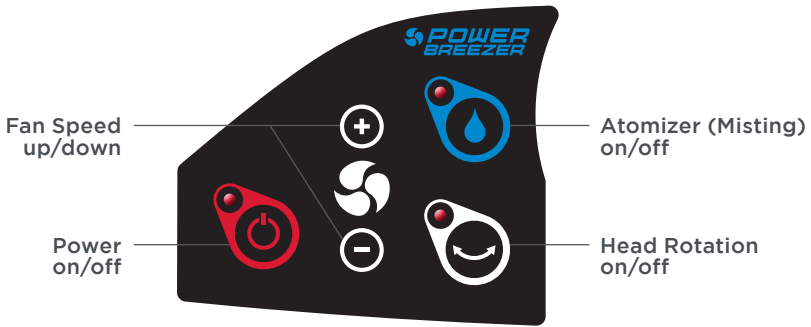

## Storage View

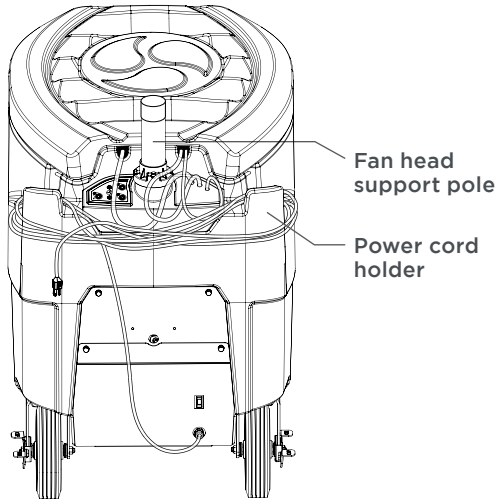

## Inside Water Tank View

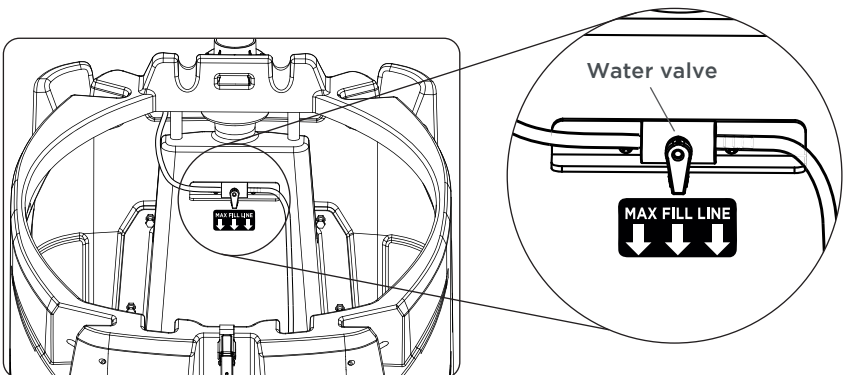

## II. SETUP

### 1. Mounting the fan head:

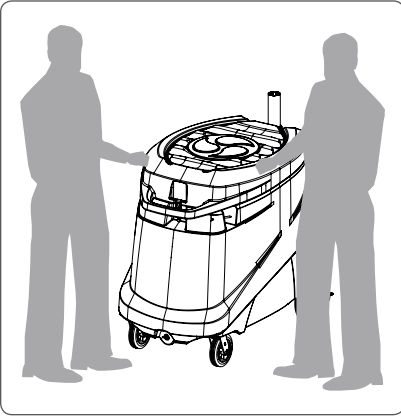

To set up your Power Breezer, you will need:

- 2 people
- An AC outlet
- Access to water to fill the **water tank**

*Remember:*

- Lift **fan head** only by the **head handles**.
- **Never** lift from the fan guards.
- **The fan head weighs 86 lbs.**

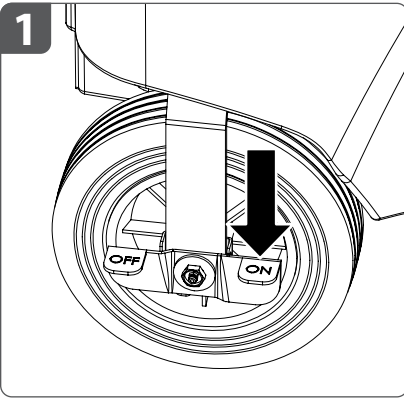

**1a.** Before you get started, be sure to **lock both** of the **rear wheels** by pressing down on the brake lever to set them to the **ON** position.

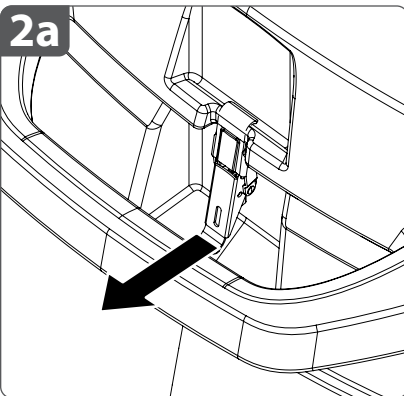

**2a.** Open the **lid latch** by first pulling forward the lower portion of the latch.

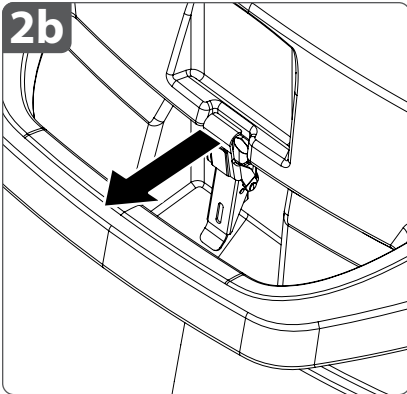

**2b.** Finish opening the **lid latch** by pulling the upper portion of the latch forward and away from the lid.

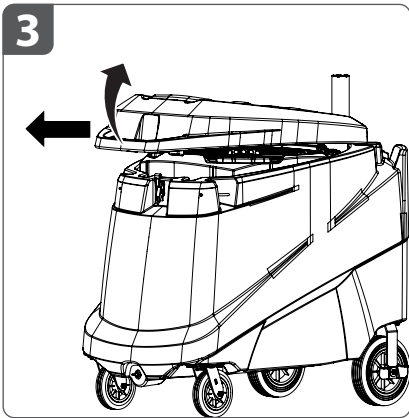

**3.** Remove **tank lid** by first lifting up on the **transport handle** and then pulling forward.

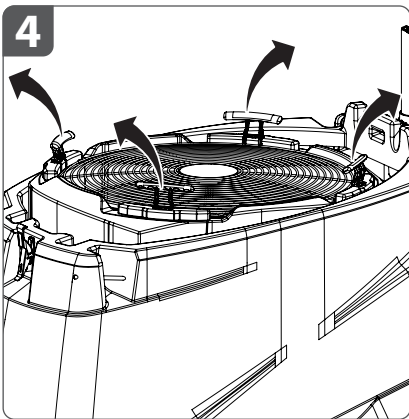

**4.** Tilt up the four **fan head handles**, if they are folded down, prior to lifting the head.

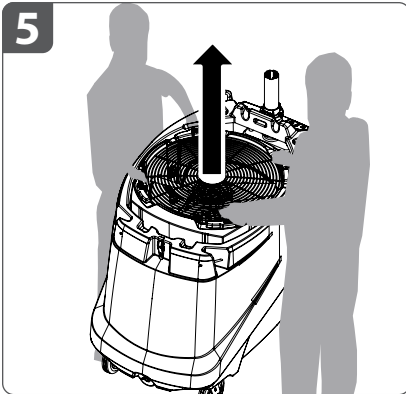

**5a.** To lift the **fan head** out of the **water tank**, each person should stand on opposite sides of Power Breezer.

**5b.** Both people should grasp the **fan head** by the **fan head handles**, as shown.

*Remember:*

- Lift **fan head** only by the **head handles**.
- **Never** lift from the fan guards.

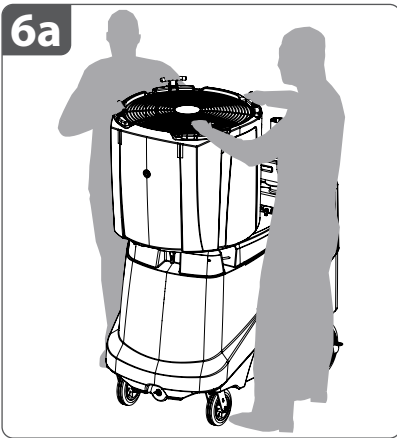

**6a.** Lift the **fan head** straight up and out of the **water tank**. Carefully rest it on the **edge of the water tank**.

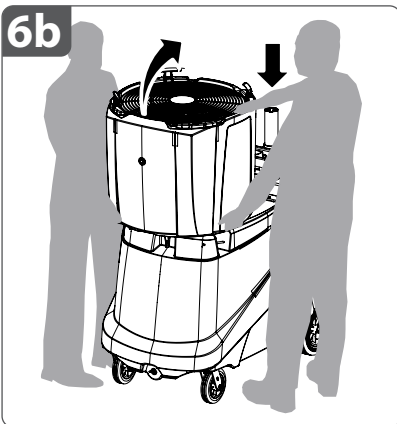

**6b.** Both people should re-adjust their grip so that they have one hand on a **fan head handle** or the black outer housing and one hand on the front edge of the **fan head**, as shown.



6c

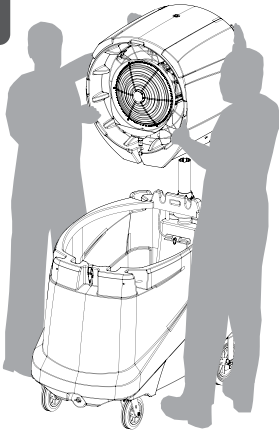

6c. Once again, lift the **fan head** and **align it with the fan head support pole**. Once the **fan head** is seated on the **support pole**, rotate the **fan head** horizontally until you feel it engage with the **support pole**.

7

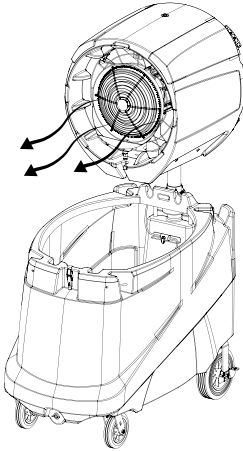



Once installed, the **atomizer** (metal disk) will be facing the **water tank**, air will be blown over the **water tank** when the Power Breezer is turned on.

## 2. Using the correct outlet:

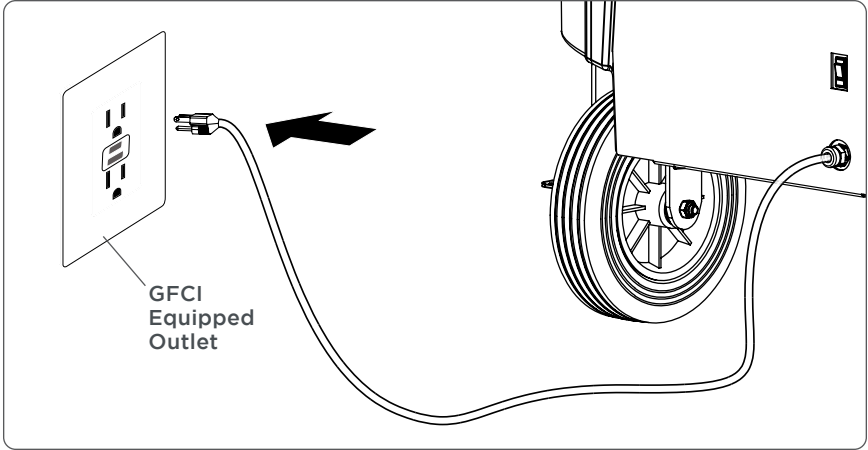
Electrical current of 110v or 220v is required. (See page 20 for Electrical Info.) For safety, only plug your Power Breezer into an outlet equipped with GFCI. **DO NOT plug into standard outlet without a GFCI feature.**



**NOTE:** A live power outlet can be verified when the Power Breezer is **plugged in and powered off** by pressing the **oscillation**  or **atomizer**  buttons. The LED lights will dimly illuminate when either of these buttons are depressed.

## 3. Adding water to the water tank:

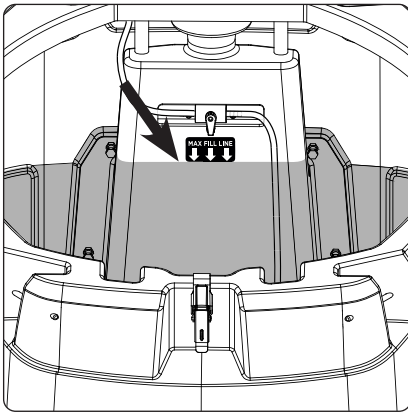

Do not fill the **water tank** above the **max fill level**, as shown. If **water tank** is filled past this level, water may leak out of the **water tank** and cause a hazard around the Power Breezer.

The **water valve** can be adjusted for optimal performance according to your climate. To adjust, please follow the steps in the **Operation - Adjusting the misting level** section of this manual.

## 4. Routing power and water lines and replacing tank lid:

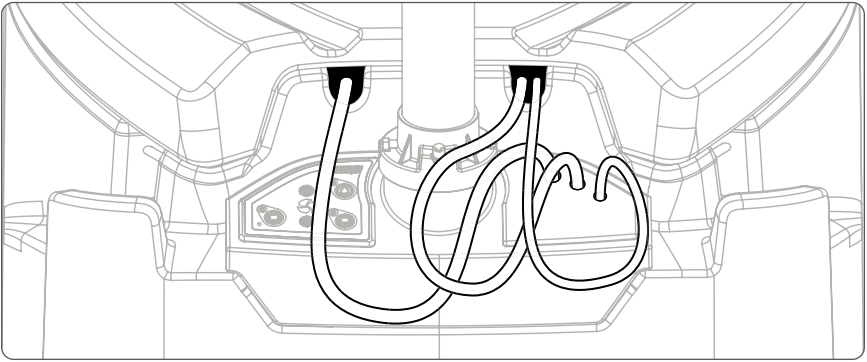

- 4a.** Route the **fan head power cord**, **atomizer drain hose**, and **water inlet hose** through the openings in the back of the **water tank** as shown above.

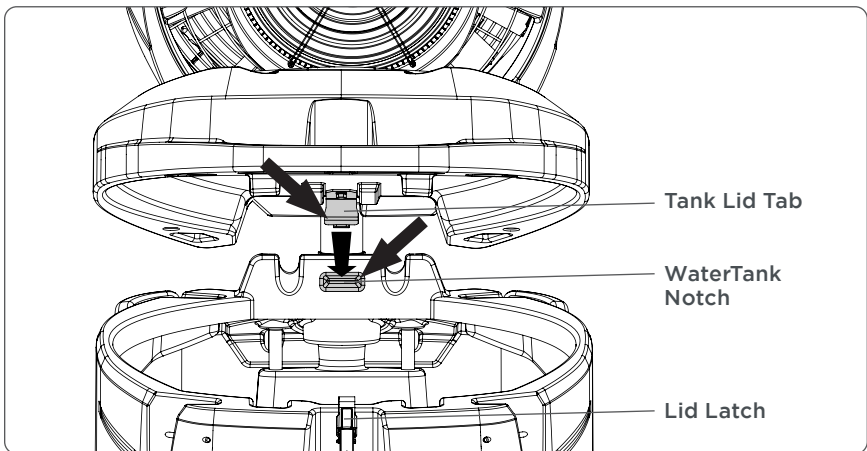

Note the **tank lid tab** on the back underside of the **tank lid**.





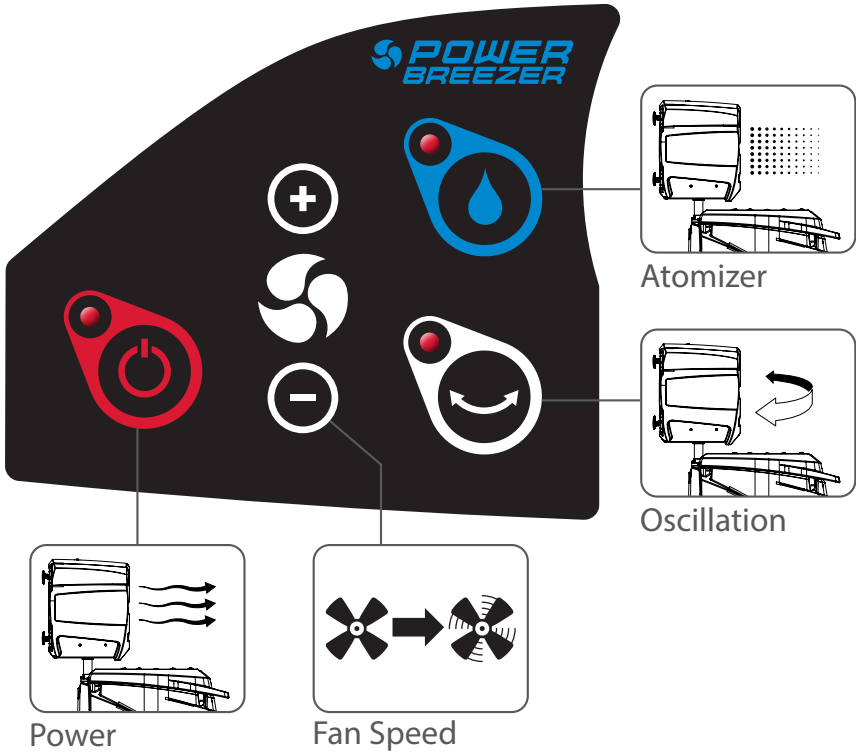

- 4b.** Slide the **lid tab** into the corresponding **water tank notch** in the back of the **water tank** as shown above.
- 4c.** Lower the front of the **tank lid** onto the **water tank** and re-lock the **lid latch**.

### III. OPERATION

#### 1. Control panel – Buttons:





#### 2. Turning on your Power Breezer:

- 2a. Press the **power button**  and **hold for one second**.  
The **LED light for the power button** will be lit and the fan blades will begin to slowly rotate to indicate the Power Breezer is powered on.
- 2b. Press the **fan speed button**  to increase the fan speed.  
Adjust the fan speed by pressing the  or  buttons.
- 2c. Press the **oscillation button**  once to activate the oscillation feature.
- 2d. Press the **atomizer button**  once to activate the misting feature.

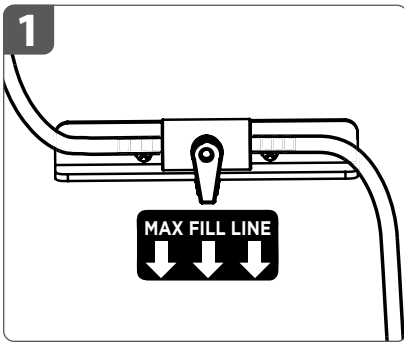
### 3. Adjusting the misting level:



- 1a. Press the **power button**  and **hold for one second** if Power Breezer is not already on.
- 1b. Set **fan speed** to desired level.
- 1c. Locate the **water valve**. The **water valve** is inside the **water tank** towards the rear.
- 1d. Start with the **water valve** closed, at the 6 o'clock position as shown.
- 1e. Start the atomizer by pressing the **atomizer button**  once.

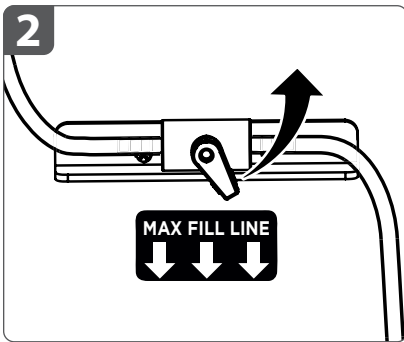

- 2a. Open the **water valve** slightly by turning the lever counter-clockwise. There will be a short delay before misting begins. Check the distance of the mist.
- 2b. If there is a strong mist at 6 feet away, then the moisture setting is too high for conditions.

To reduce misting, rotate the **water valve** lever clockwise back towards the 6 o'clock position.

*Optimal moisture settings can also be adjusted according to personal preference.*

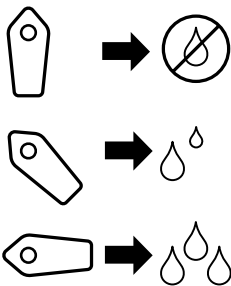

## IV. DISASSEMBLY

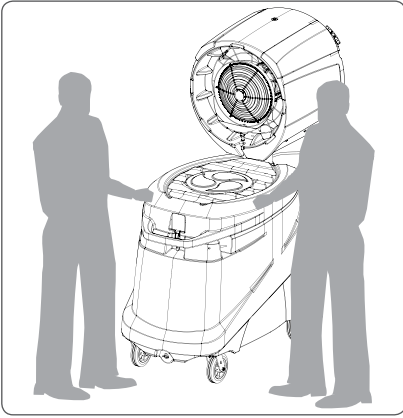



To disassemble your Power Breezer, you will need:

- 2 people

*Remember:*

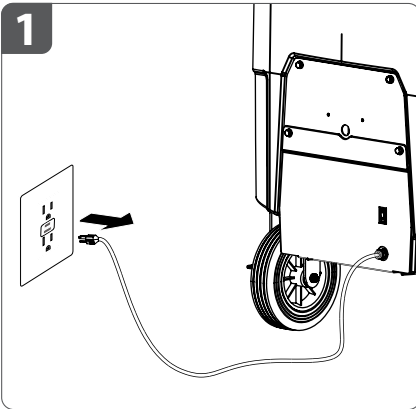
- Lift **fan head** only by the black outer shell from the top and bottom.
- **Never** lift from the fan guards or metal disk.
- **The Fan Head weighs 86 lbs.**



**1a.** Power off the Power Breezer by holding down the **power button**  for one second.

**1b.** Unplug **power cord**.

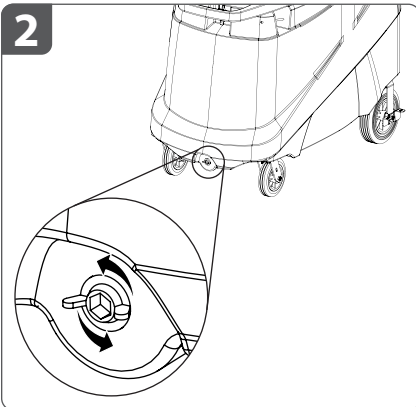

**Drain water tank:**

Depending on the volume of water to be drained, you may want to move your Power Breezer to a suitable location prior to draining.

Open the **drain plug** by turning counter clockwise and fully drain the **water tank**.

## 1. Dismounting fan head:

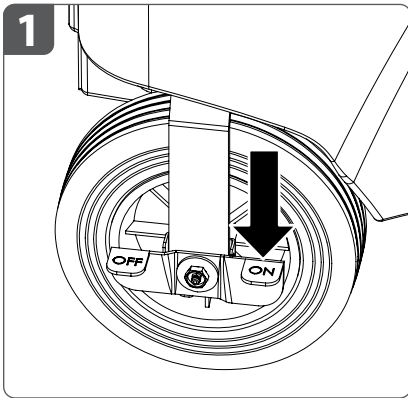

Before you get started, be sure to lock both of the **rear wheels** by pressing down on the brake lever to set them to the **ON** position.

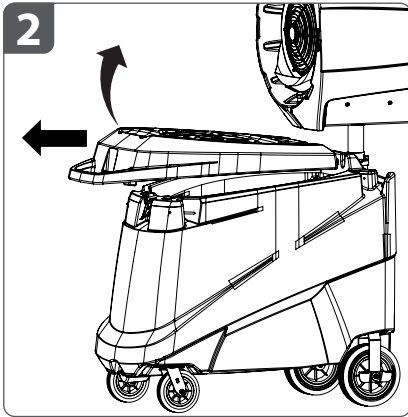

**2a.** Unlock lid latch.

**2b.** Remove the **tank lid** by first lifting up on the **transport handle** and then pulling forward.

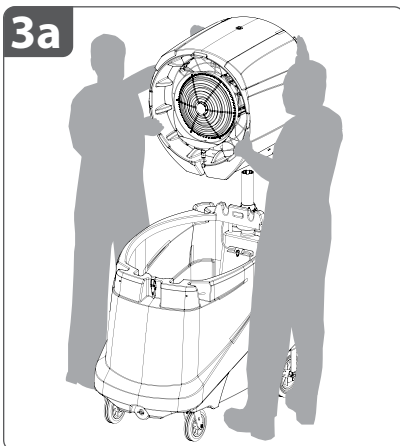

**3a.** Lift the **fan head** straight up and off the **head support pole**.

**3b**

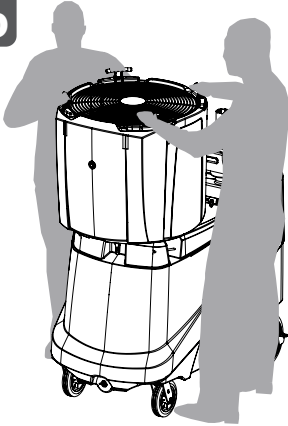

**3b.** Carefully rest the **fan head** on the **edge of the tank**.

Both people should grasp the **fan head** by the **fan head handles**, as shown.

*Remember:*

- At this step, lift the **fan head** only by the **head handles**.
- **Never** lift from the fan guards.

**3c**

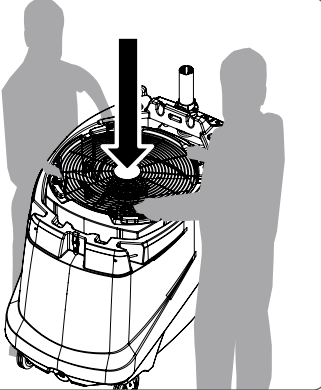

**3c.** Carefully lower the **fan head** into the **water tank**.



## 2. Routing power and water lines and replacing tank lid:

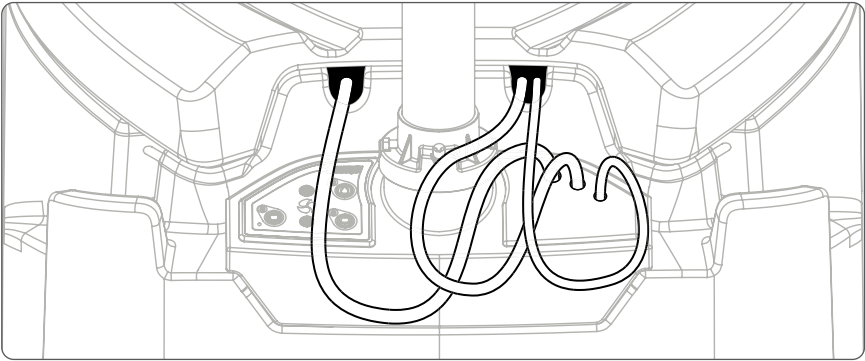

- 2a.** Route the **fan head power cord, atomizer drain hose, and water inlet hose** through the openings in the back of the **water tank** as shown above.

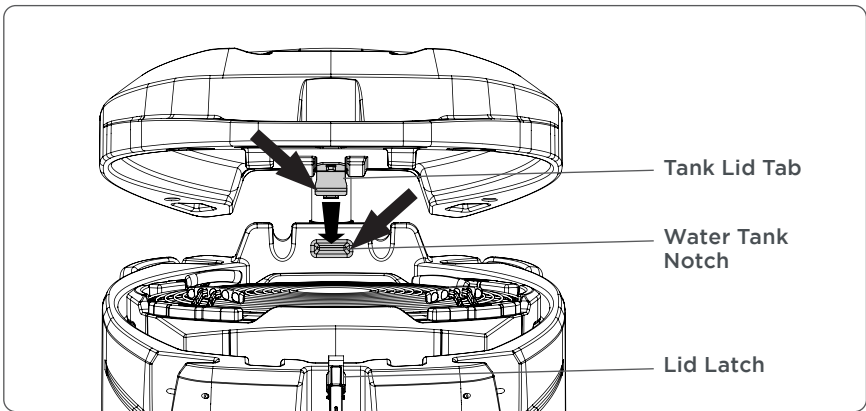

Note the **lid tab** on the back underside of the **lid**.

- 2b.** Slide the **lid tab** into the corresponding **water tank notch** in the back of the **water tank** as shown above.
- 2c.** Lower the front of the **lid** onto the **water tank** and re-lock the **lid latch**.

## V. MOVING / TRANSPORTING YOUR POWER BREEZER

**DO NOT reposition or move** your Power Breezer by the **fan head** (if mounted) or the **fan head support pole** (if stored). Doing so may damage your Power Breezer. Only reposition or move your Power Breezer by the **transport handle**.

Prior to transporting your Power Breezer over long distances, disassemble the Power Breezer to prevent damage. Use the **tie down points** to limit movement and prevent damage. Also make sure both **rear wheel locks** are engaged in the **ON position** to prevent rolling.

For long-term storage, make sure that the **water tank** is fully dry. If it is not dry, you may use the fan to dry it.

- With the **fan head** in the **water tank**, and the **tank lid removed**, turn on the fan using a medium speed until the **water tank** is dry.

## VI. MAINTAINING YOUR POWER BREEZER

For the best performance and longest life of your Power Breezer, we recommend the following maintenance on your Power Breezer every **30 days** and **prior to storing for extended periods of time**.

### 1. Maintaining the water tank:

- The Power Breezer was designed with easy cleaning in mind.
- Once a week drain the **water tank** and allow for the **water tank** to dry out overnight.
- If the inside of the **water tank** becomes slippery/slimy to the touch, drain the Power Breezer. You can also clean the **water tank** by putting a few drops of liquid soap in water and brushing the inside of the **water tank** with it. Rinse the **water tank** with a hose, then open the **drain plug** at the bottom and leave the **tank lid** off to allow to air dry.

### 2. Maintaining the fan head and motor:

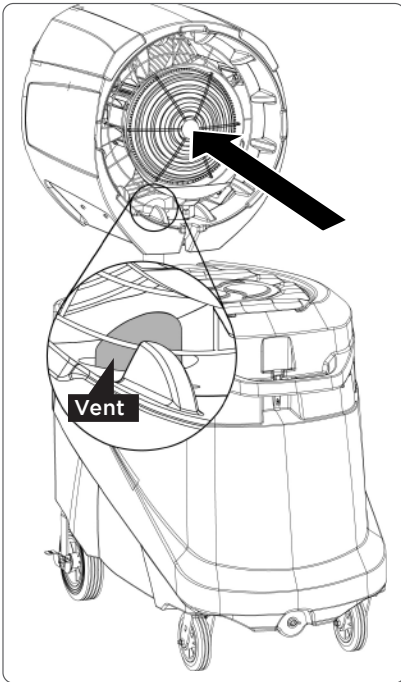

If you see a collection of dust or debris in the head of the Power Breezer, clean the Power Breezer with a water hose.

**Spray from the front of the fan head.** Use a clean cloth to wipe it down.

Avoid spraying water directly into the **vent**.

## VII. ELECTRICITY FOR YOUR POWER BREEZER

Your Power Breezer Mach 4+ Universal is designed so that it can be used in both a 110 or a 220 voltage electrical system.

For example:

- Original plug: 110v, Plug Type B, as used in the United States
- Changed to: 220v, Plug Type G, as used in England

If you need the unit to operate in a voltage that does not match its provided power plug, a good long-term solution is to order a power cord with the appropriate plug.

- Order online at:  
<https://www.powerbreezer.com/parts/>
- Contact your retail seller or distributor.

\*Note: Limited types of power cord types are produced and not every configuration is available

## VIII. WARRANTY

### Power Breezer Limited Warranty

---

#### **WHAT IS COVERED:**

Power Breezer. ("Manufacturer") warrants the following products:

#### **Power Breezer Mobile**

for the Coverage Period of One (1) year for all of the Unit's components have a warranty to be free from defects in materials or workmanship.

#### **WHO IS COVERED:**

This Limited Warranty extends only to the first purchaser ("Buyer") and is not transferable. The Warranty coverage starts from the date of shipment to the Buyer. Under no circumstances will warranty coverage extend to products purchased through eBay, Craigslist, or other internet auction or internet-based retail sites not approved by Manufacturer. This Warranty is only valid within the 50 states of the United States and the District of Columbia.

#### **WHAT WILL THE MANUFACTURER DO:**

Within 30 days after receipt of a claim made on a product still within the warrantable Coverage Periods, the Manufacturer shall have the option either to inspect the product while in it is still in the Buyer's possession or to request the Buyer to return the product to a specified service center at Buyer's expense for an inspection. Any components found, upon a detailed examination by factory authorized personnel, to be defective in either material or workmanship will be repaired or replaced with functioning new or remanufactured parts at Manufacturer's or authorized dealer's option and without a charge.

Manufacturer is not responsible for the cost of removal of the defective product or part, damages due to removal, or any expenses incurred in shipping the product or part to or from the Unit's location, or the installation of the repaired or replaced product or part. Transportation charges on parts submitted for replacement or repair under this warranty shall be borne by the Buyer.

The aforementioned constitutes the extent of your Remedy under this Limited Warranty and the limit of liability for Manufacturer, and for any and all losses in connection with this product.

#### **BUYER'S HOW TO MAKE A CLAIM:**

Any and all repairs and replacements must be performed by or under the

instruction of the Manufacturer, authorized dealer and or representative. All warranty claims must be made ASAP after a defect is discovered, but before the end of the warranty coverage on that part. When a warranty claim is submitted by the Purchaser and approved by the Manufacturer, the Manufacturer may choose to replace the Unit, ship the Unit to the Manufacturer's warehouse for repair, or dispatch a field service representative to the Purchaser's site for repair..

THESE WARRANTIES ARE THE ONLY EXPRESS WARRANTIES BY MANUFACTURER ON THE UNIT. THESE WARRANTIES ARE LIMITED IN DURATION TO THE TIME PERIOD(S) OF THESE EXPRESSED WRITTEN WARRANTIES. THESE WARRANTIES ARE IN LIEU OF ALL OTHER OBLIGATIONS, LIABILITIES OR WARRANTIES, WHETHER EXPRESS OR IMPLIED. THESE WARRANTIES DO NOT COVER:

- (1) NORMAL DETERIORATION OR FADING OF COLOR, COSMETIC OR APPEARANCE ITEMS;
- (2) DAMAGE OR MALFUNCTION DUE TO IMPROPER REPAIR DUE TO ANY UNAUTHORIZED ALTERATION OR MODIFICATION MADE TO THE UNIT;
- (3) DAMAGE OR MALFUNCTION DUE TO ABUSE, NEGLIGENCE, ACCIDENT OR FIRE;
- (4) DAMAGE CAUSED BY A NON-COVERED, UNAUTHORIZED PART; AND
- (5) FAILURE TO FOLLOW MANUFACTURER'S CLEANING AND MAINTENANCE GUIDELINES. MANUFACTURER AND ITS AUTHORIZED DEALERS AND DISTRIBUTORS SHALL NOT BE LIABLE FOR ANY LOSS OF USE OF THE COOLING UNIT, FOR ANY ALTERNATE EQUIPMENT, FOR ANY DAMAGE TO GOODS, COMMERCIAL LOSS, LOSS OF TIME OR INCONVENIENCE, OR FOR ANY OTHER INCIDENTAL OR CONSEQUENTIAL DAMAGES.

For more information, please visit [www.PowerBreezer.com](http://www.PowerBreezer.com)

Make a claim, please visit [www.powerbreezer.com/warranty-claim/](http://www.powerbreezer.com/warranty-claim/)

## IX. CONTACT INFORMATION

### General Information or Product/Installation Support

Email: [customerservice@powerbreezer.com](mailto:customerservice@powerbreezer.com)

Phone: 844.233.5673, Option 1

Visit: [PowerBreezer.com/support](http://PowerBreezer.com/support)

### For Sales Information

[sales@powerbreezer.com](mailto:sales@powerbreezer.com)

Phone: 844.233.5673

### User Videos

[www.youtube.com/powerbreezer](http://www.youtube.com/powerbreezer)

[www.powerbreezer.com](http://www.powerbreezer.com)

### Follow Us

[www.linkedin.com/company/2561996](http://www.linkedin.com/company/2561996)

[www.facebook.com/PowerBreezer](http://www.facebook.com/PowerBreezer)

[www.twitter.com/PowerBreezer](http://www.twitter.com/PowerBreezer)



[PowerBreezer.com](https://PowerBreezer.com)

4835 Sirona Drive, Suite 400  
Charlotte, NC 28273

©2022 Maxify Solutions, Inc.  
All Rights Reserved.

Power Breezer® is licensed under  
U.S. Patent No. 6,789,787.

